

SIEMENS



i-Con Switchgear Condition Monitoring

HV Switchgear Integrated Substation Condition Monitoring – ISCM™

Answers for Infrastructure.



The challenge:

Reliable energy supply is the key to success for every enterprise in a globalized industrial world. Grid owners, utilities and industrial customers today face a number of unique challenges: expenditure cuts, loss of knowledge and expertise through retirement or downsizing. Furthermore operating aging equipment at higher levels affects lifespan and reliability. Yet, customers are expected to maintain the same level of performance.

The need for condition monitoring solutions has never been greater than it is now.

The ability to easily obtain information that will enable accurate prediction of intervention time and clear guidance of the intervention required means that you can face these unique challenges with greater confidence.

The primary goals are:

- **Reduced life cycle costs**
Through lower maintenance costs, reduced expenditure for spare parts, and extended component life.
- **Easy implementation**
In your existing substation infrastructure through modular design.
- **Avoidance of penalties**
Through effective prediction and prevention of equipment failures.
- **Environmental Benefits**
Through prevention of environmentally hazardous conditions.



Siemens offers three levels for HV switchgear monitoring and diagnostics



Expert support via
Service Level Agreements



Integrated Substation
Condition Monitoring



i-Con Stand-alone
solution for GIS and AIS

Our solution:

The i-Con switchgear online monitoring solution

Siemens i-Con: Helping you to avoid the consequences of failure in the most critical situations.

The Siemens i-Con range of solutions forms the basis of the GIS & Switchgear Monitoring modules within the Siemens Integrated Substation Condition Monitoring System (ISCM™), offering a sophisticated and comprehensive condition monitoring concept covering all equipment present within the power supply network from the switchgear itself to the transformers, cable and overhead lines.

Siemens i-Con Condition Monitoring solutions have been developed for use on switchgear for GIS and AIS applications from 66 kV up to 800 kV. Siemens has been involved in the field of switchgear Condition Monitoring for over 30 years and manufacturing solutions for the industry for over 20 years.

Your benefits at a glance:

- Improved reliability through early detection of impending failure.
- Avoidance of unplanned outages.
- Reduction of repair costs through improved failure detection.
- Improved availability.
- Supporting a more efficient, cost effective and proactive maintenance strategy.

i-Con PDM

UHF Partial Discharge
Monitoring

i-Con CBM

Circuit Breaker
Monitoring

i-Con GDM

SF₆ Gas Density
Monitoring

The i-Con range of solutions covers all essential monitoring elements for both GIS and AIS. Each i-Con element is a solution of its own. However, all of them are based on an integrated software platform offering full flexibility to the customer.

Each i-Con package is modular by design and easily extendable which is achieved by concentrating sensor data in Node Unit Cubicles. This design allows for a very simple communications connection to transmit all of the bay data along a single fibre cable to the System Control Cubicle/HMI where data can be accessed and alarms are automatically generated.

The integrated software platform enables the integration of further substation assets, such as transformers, cables and overhead lines. This common platform forms the basis of the Siemens Integrated Substation Condition Monitoring (ISCM™) System. The HMI not only provides a fast and user-friendly front-end overview, it also incorporates powerful expert modes, whereby detailed investigation can take place e.g. trend analysis, automated reporting and defect location.

The i-Con^{PDM} – UHF Partial Discharge Monitoring System is the third generation of PD monitoring systems developed for GIS.

The system facilitates measurements using internal or external UHF sensors and supports compliance with IEC requirements for High Voltage onsite testing using partial discharge monitoring. The UHF transducer comprises:

- UHF Sensor with UHF Cable
- UHF Signal Filtering and Optical Processor

The specially designed optical signal conditioning modules provide the data input to the data acquisition system in the Node Unit.

Each Node Unit is capable of processing data for 48 UHF inputs. Typically, this allows one Node unit to concentrate and process data for up to four GIS Switchgear bays.

It is also possible to perform Partial Discharge localization with the application of a Siemens portable Dialoc System.

The i-Con^{CBM} – Circuit Breaker Monitoring System can be applied for both AIS and GIS equipment. The system is highly flexible and covers a wide range of Circuit Breaker monitoring functions.

The Circuit Breaker components that are monitored are generally customer defined, based on key user-specific parameters, however, typically as follows:

- CB Mechanism Pressure
- Trip & Close Coil Currents
- Auxiliary DC Supply Voltage
- AC Phase Currents & Voltages
- Auxiliary Switches
- CB Bay Temperature

The i-Con^{CBM} Node Unit has been specifically designed to facilitate all measurements associated with the operation of one bay of switchgear, thus maintaining the i-Con modular approach. In order to simplify signal cabling for AIS applications, the monitoring equipment can be located in the Circuit Breaker Local Control Cubicle or directly into an i-Con Node Unit.

The i-Con^{GDM} – SF₆ Gas Density Monitoring System has been designed to allow the user a greater degree of flexibility for measurements and alarms than that currently provided by gauges with contacts.

The system uses SF₆ density transducers which operate with a 4 to 20mA current loop technology for high noise immunity. The result is a full SF₆ inventory management system capable of providing advance warning of SF₆ leaks with an accuracy of 0.5% per annum.

Transducers can be mounted directly to the GIS chamber via an industry standard gas “top-up” connection or retrofitted to gas monitoring boxes housing SF₆ gas pressure gauges where ease of access is a requirement.

Transducers are connected to an i-Con Node Unit installed within the GIS Hall. Up to 45 Density transducers can be connected to each Node Unit which houses the data acquisition and storage facilities.

Standard central control cubicle:

Weight: 350 kg

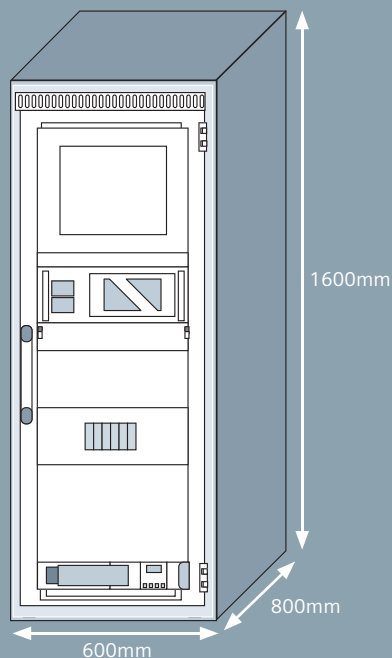

i-Con Node Unit:

Weight: 65 kg

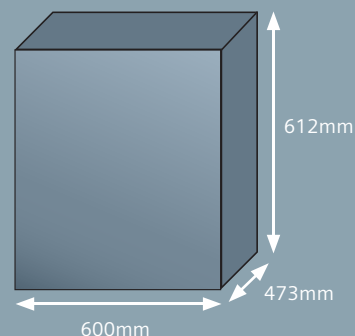

Technical data and dimensions

	iCon ^{PDM}	iCon ^{GDM}	iCon ^{CBM}
Inputs:			
Analogue inputs:	48 inputs / node	45 inputs / node	50 inputs / node
Input type:	UHF optical transducer	2 wire 4-20 mA current loop	Various – user defined inputs
Communication system:	Fast ethernet IEEE 802.3u Gigabit ethernet IEEE 802.3z TCP/IP network protocol Compatibility to major communication standards (e.g. IEC 61850, DNP3)		
Output:			
Alarms and Reports:	3 x PD level alarms (software selectable) PD diagnostic tools System failure alarms	SF6 leak detected SF6 1st & 2nd stage alarm Gas inventory reporting System failure alarms	User defined and selectable based on monitoring criteria. System failure alarms
Software:			
Platform:	Microsoft Windows		
Base software:	Siemens Sicam 230 with ISCM run-time environment		
Recording:			
Sampling rate:	5 kS/s per input	10 S/s per input	5 kS/s per input
Power:			
Operating voltage:	90 to 260 V, 47 to 63 Hz		
Power requirement:	Approx. 260 W		
EMI testing / environmental:			
Fully EMI tested – full details on test available on request			
Enclosure protection rating:	-5 to +55°C (indoor)		
Operating temperature range:	5 to 95% non-condensing		
Humidity:	IP55 (For achieving IP65 rating, the Node Unit can be installed within a climate controlled cabinet)		

Published by and copyright © 2011:
Siemens Transmission and Distribution Limited
7 North Farm Road
Hebburn
Tyne & Wear
NE 31 1LX
United Kingdom

For more information, contact our Customer Support Center
Phone: +49 180/524 70 00
Fax: +49 180/524 2471
e-mail: support.energy@siemens.com

All rights reserved.
Trademarks mentioned in this document are the property of
Siemens AG, its affiliates, or their respective owners.

Subject to change without prior notice.
The information in this document contains general
descriptions of the technical options available, which may
not apply in all cases. The required technical options should
therefore be specified in the contract.